

**1330nm 1.5W Laser Diode with H-mount Package | FAC Lens Optional | Hermetic Package
 1320nm~1330nm| 1.5W Output Power | Window Package | Square or Line Beam Optional
 WSLD-1330-1500m-H**

Wavespectrum Laser Group

www.wavespectrum-laser.com

1330nm Laser Diode		1.5W/H-mount		Wavespectrum Laser Group	
PARAMETER	SYMBOL	VALUE	UNIT		
Reverse Voltage	V_r	2.0	V		
Operating Temperature	T_{op}	+10~+30	°C		
Storage Temperature	T_{stg}	-20~+80	°C		
Lead soldering temperature (10 sec.)	T_{is}	260	°C		
Features: <ul style="list-style-type: none"> 1330nm 1.5W Power H-mount Package (Window Package) FAC Lens Optional (Square or Line Beam) 					
Applications: <ul style="list-style-type: none"> Medical Laser Treatment Others 					
Specifications		WSLD-1330-1500m-H			
		Min	Type	Max	
Center Wavelength@25°C		+/-10nm	1330nm	+/-30nm	
Spectral Width (FWHM)		----	6.0nm	10.0nm	
Output Power		----	1.5W	----	
Emitter Area		----	85x1µm	----	
Beam Divergence (With FAC Lens)		----	8° _⊥ x 28° _{//}	----	
Temperature Coefficient of Wavelength		----	0.7nm / °C	----	
Slope Efficiency		----	0.5W/A	----	
Threshold Current (Typ.)		----	0.4A	0.7A	
Operating Current (Typ.)		----	3.3A	3.5A	
Operating Voltage		----	1.3V	1.5V	
Package Style		H-mount			
Recommended Operating Temperature		25°C			



H-mount Package

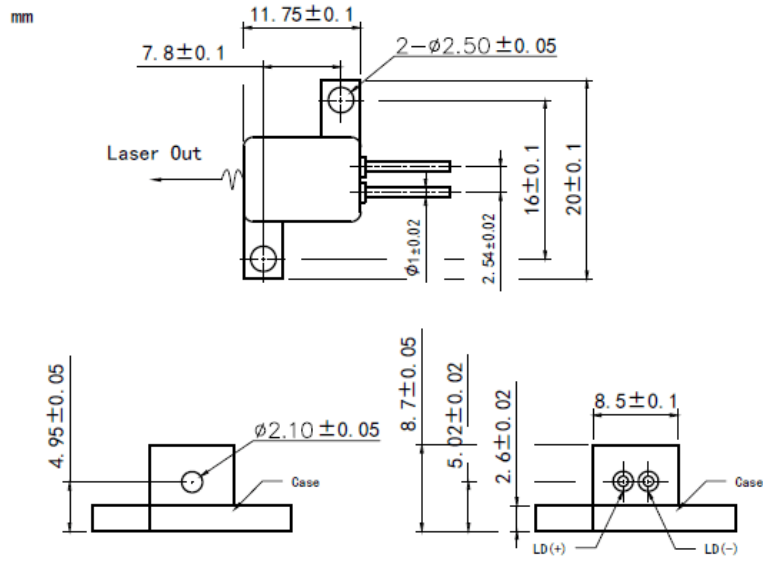

Electrically shorten LD module and store in non-extreme conditions.

Suggest using the constant current power supply.

